

# G3 Standard Automatic Lubrication Pump

332291F

EN

*For dispensing of NLGI Grades #000 to #2 greases and oil with at least 40cSt. For Professional Use Only.*

*Not approved for use in explosive atmospheres or hazardous locations.*

## Part Nos., page 3

5100 psi (35.1 MPa, 351.6 bar) Pump Output Pressure

5000 psi (34.4 MPA, 344.7 bar) Fill Inlet Pressure

### Important Safety Instructions

Read all warnings and instructions in this manual. Save these instructions.

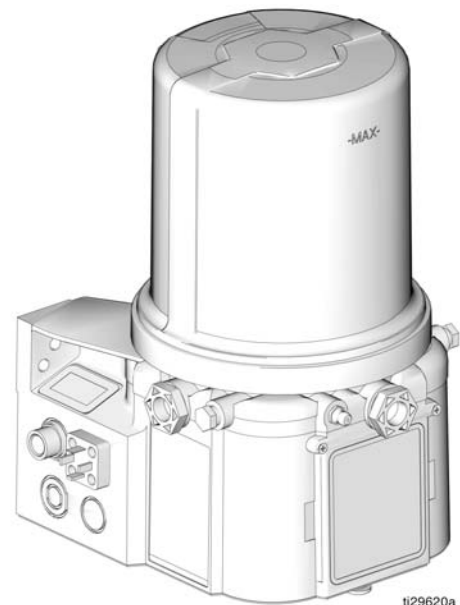

Conforms to ANSI/UL 73  
Certified to CAN/CSA  
Std. 22.2 No 68-09



# Contents

<b>Part / Model Numbers</b> .....	<b>3</b>
2 Liter Models .....	3
4 Liter Models .....	3
8 Liter Models .....	3
12 Liter Models .....	3
16 Liter Models .....	3
Understanding the Model Number .....	4
<b>Warnings</b> .....	<b>5</b>
<b>Installation</b> .....	<b>7</b>
Typical Installation .....	8
Typical Installation - With Remote Fill Manifold ..	9
Optional Installation -	
Without Remote Fill Manifold .....	10
Choosing an Installation Location .....	11
System Configuration and Wiring .....	12
Wiring and Installation Diagrams .....	13
<b>Setup</b> .....	<b>18</b>
Connecting to Auxiliary Fittings .....	18
Setting Pump Outlet Volume .....	19
Loading Grease .....	19
Auto-Fill Shut Off .....	21
Filling Oil Unit .....	23
Priming .....	24
<b>Pump Operation</b> .....	<b>25</b>
<b>Troubleshooting</b> .....	<b>27</b>
<b>Maintenance</b> .....	<b>28</b>
<b>Parts - 2 Liter Models</b> .....	<b>29</b>
<b>Parts - 4 Liter and Larger Models</b> .....	<b>30</b>
<b>Parts</b> .....	<b>31</b>
<b>Technical Data</b> .....	<b>34</b>
Dimensions .....	34
Mounting Pattern .....	35
<b>Graco Standard Warranty</b> .....	<b>36</b>
Graco Information .....	36

## Part / Model Numbers

The Part Number is a six-digit unique number that is only used to order the G3 Pump. Directly related to this six digit Part Number is the configured Graco Model Number. This configured number identifies the distinct features of a specific G3 Pump. To help you understand each component that makes up the Model Number see Understanding Your Model Number, page 4. The tables below shows the relationship between each Part Number and its related Model Number.

### 2 Liter Models

Part Numbers	Model Number
96G000	G3-G-12NC-2L0000-00C00000
96G001	G3-G-24NC-2L0000-00C00000
96G002	G3-G-ACNC-2L0000-0D000000
96G003	G3-G-12NC-2L0A00-L0C00000
96G005	G3-G-24NC-2L0A00-L0C00000
96G006	G3-G-24NC-2LFA00-L0C00000
96G007	G3-G-ACNC-2L0A00-LD000000
96G008	G3-G-ACNC-2LFA00-LD000000
96G050	G3-A-24NC-2L0A00-L0C00000
96G059	G3-A-ACNC-2L0A00-LD000000
96G182	G3-G-24NC-2L0A00-0D00L000

### 4 Liter Models

Part Numbers	Model Number
96G038	G3-G-12NC-4L0L00-00C00000
96G040	G3-G-24NC-4L0000-00C00000
96G042	G3-G-ACNC-4L0000-0D000000
96G044	G3-G-12NC-4L0A00-L0C00000
96G048	G3-G-24NC-4L0A00-L0C00000
96G051	G3-A-24NC-4L0A00-L0C00000
96G053	G3-G-24NC-4LFA00-L0C00000
96G055	G3-G-ACNC-4L0A00-LD000000
96G060	G3-A-ACNC-4L0A00-LD000000
96G062	G3-G-ACNC-4LFA00-LD000000
96G179	G3-G-ACNC-4LFA00-0D00L000
96G184	G3-G-24NC-4L0A00-0D00L000
96G210	G3-G-24NC-4LAA00-0D00L000

### 8 Liter Models

Part Numbers	Model Number
96G039	G3-G-12NC-8L0000-00C00000
96G041	G3-G-24NC-8L0000-00C00000
96G043	G3-G-ACNC-8L0000-0D000000
96G045	G3-G-12NC-8L0A00-L0C00000
96G049	G3-G-24NC-8L0A00-L0C00000
96G052	G3-A-24NC-8L0A00-L0C00000
96G056	G3-G-ACNC-8L0A00-LD000000
96G061	G3-A-ACNC-8L0A00-LD000000
96G187	G3-G-ACNC-8LFA00-0D00L000
96G198	G3-G-24NC-8L0A06-0C000000
96G207	G3-G-ACNC-8LAA00-LD000000
96G213	G3-G-24NC-8LAA00-0D00L000
96G217	G3-G-24NC-8LAA06-00C00000

### 12 Liter Models

Part Numbers	Model Number
96G057	G3-G-ACNC-120A00-LD000000
96G171	G3-G-24NC-120000-00C00000

### 16 Liter Models

Part Numbers	Model Number
96G058	G3-G-ACNC-160A00-LD000000
96G172	G3-G-24NC-160000-00C00000

## Understanding the Model Number

Use the Code Sample provided below to identify each component's location in the Model Number. The options for each component that make up the code are provided on the lists below.

**NOTE:** Other pump configurations are available that are not documented in this manual. Contact Graco Customer Service or your local Graco distributor for assistance.

Code Sample:  $\frac{G}{a} \frac{3}{a} - \frac{G}{b} - \frac{N}{b} \frac{C}{b} - \frac{0}{c} \frac{0}{c} \frac{0}{d} \frac{0}{e} \frac{0}{f} \frac{0}{f} - \frac{0}{g} \frac{0}{h} \frac{0}{i} \frac{0}{j} \frac{0}{k} \frac{0}{m} \frac{0}{n} \frac{0}{p}$

**G3 - G = Identifies pump as being a G3; G = Grease**  
**G3 - A = Identifies pump as being a G3; A = Oil**

**Code aa: Power Source**

- 12 = 12 Volts DC
- 24 = 24 Volts DC
- AC = 100 - 240 Volts AC

**Code bb: Operation Control**

- NC = No Controller

**Code cc: Reservoir Capacity (Liters)**

- 2L = 2 Liters
- 4L = 4 Liters
- 8L = 8 Liters
- 12 = 12 Liters
- 16 = 16 Liters

**Code d: Follower Plate Installed**

- F = Follower Plate Installed
- 0 = No Follower Plate
- A = Auto-Fill Shut Off

**Code e: Low Level Option**

- A = External Low Level
- 0 = No Low Level monitoring

**Code ff: Options**

- 00 = No Options
- 06 = Low Level in CPC

**Code g, h, i, j, k, m, n, p**

**NOTE: Codes g - p** relate to a specific location on the G3 pump. See **FIG. 1** for these locations.



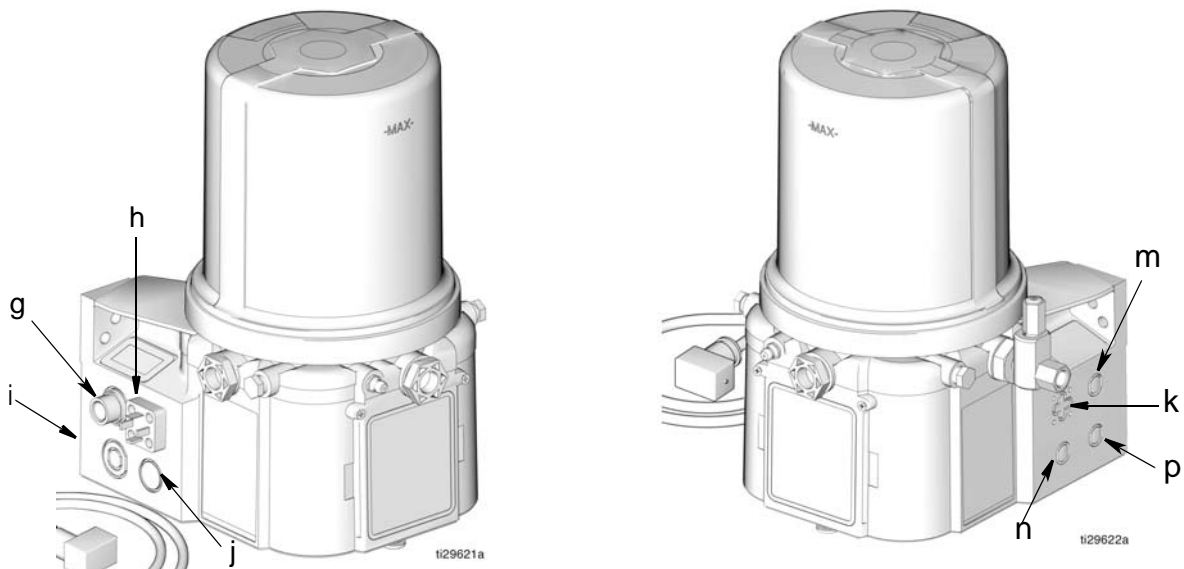

- C = CPC
- D = DIN
- L = Low Level
- 0 = Not populated



**FIG. 1**





# Warnings

The following warnings are for the setup, use, grounding, maintenance, and repair of this equipment. The exclamation point symbol alerts you to a general warning and the hazard symbols refer to procedure-specific risks. When these symbols appear in the body of this manual or on warning labels, refer back to these Warnings. Product-specific hazard symbols and warnings not covered in this section may appear throughout the body of this manual where applicable.

 <b>WARNING</b>	
 	<p><b>ELECTRIC SHOCK HAZARD</b></p> <p>This equipment must be grounded. Improper grounding, setup, or usage of the system can cause electric shock.</p> <ul style="list-style-type: none"> <li>• Turn off and disconnect power at main switch before disconnecting any cables and before servicing or installing equipment.</li> <li>• Connect only to grounded power source.</li> <li>• All electrical wiring must be done by a qualified electrician and comply with all local codes and regulations.</li> </ul>
 	<p><b>EQUIPMENT MISUSE HAZARD</b></p> <p>Misuse can cause death or serious injury.</p> <ul style="list-style-type: none"> <li>• Do not operate the unit when fatigued or under the influence of drugs or alcohol.</li> <li>• Do not exceed the maximum working pressure or temperature rating of the lowest rated system component. See <b>Technical Data</b> in all equipment manuals.</li> <li>• Use fluids and solvents that are compatible with equipment wetted parts. See Technical Data in all equipment manuals. Read fluid and solvent manufacturer's warnings. For complete information about your material, request MSDS from distributor or retailer.</li> <li>• Turn off all equipment and follow the <b>Pressure Relief Procedure</b> when equipment is not in use.</li> <li>• Check equipment daily. Repair or replace worn or damaged parts immediately with genuine manufacturer's replacement parts only.</li> <li>• Do not alter or modify equipment. Alterations or modifications may void agency approvals and create safety hazards.</li> <li>• Make sure all equipment is rated and approved for the environment in which you are using it.</li> <li>• Use equipment only for its intended purpose. Call your distributor for information.</li> <li>• Route hoses and cables away from traffic areas, sharp edges, moving parts, and hot surfaces.</li> <li>• Do not kink or over bend hoses or use hoses to pull equipment.</li> <li>• Keep children and animals away from work area.</li> <li>• Comply with all applicable safety regulations.</li> </ul>



# WARNING

	<p><b>SKIN INJECTION HAZARD</b></p> <p>High-pressure fluid from dispensing device, hose leaks, or ruptured components will pierce skin. This may look like just a cut, but it is a serious injury that can result in amputation. <b>Get immediate surgical treatment.</b></p> <ul style="list-style-type: none"> <li>• Do not point dispensing device at anyone or at any part of the body.</li> <li>• Do not put your hand over the fluid outlet.</li> <li>• Do not stop or deflect leaks with your hand, body, glove, or rag.</li> <li>• Follow the <b>Pressure Relief Procedure</b> when you stop dispensing and before cleaning, checking, or servicing equipment.</li> <li>• Tighten all fluid connections before operating the equipment.</li> <li>• Check hoses and couplings daily. Replace worn or damaged parts immediately.</li> </ul>
	<p><b>PRESSURIZED EQUIPMENT HAZARD</b></p> <p>Over-pressurization can result in equipment rupture and serious injury.</p> <ul style="list-style-type: none"> <li>• A pressure relief valve is required at each pump outlet.</li> <li>• Follow <b>Pressure Relief Procedure</b> in this manual before servicing.</li> </ul>
	<p><b>PLASTIC PARTS CLEANING SOLVENT HAZARD</b></p> <p>Many solvents can degrade plastic parts and cause them to fail, which could cause serious injury or property damage.</p> <ul style="list-style-type: none"> <li>• Use only compatible water-based solvents to clean plastic structural or pressure-containing parts.</li> <li>• See <b>Technical Data</b> in this and all other equipment instruction manuals. Read fluid and solvent manufacturer's MSDSs and recommendations.</li> </ul>
	<p><b>MOVING PARTS HAZARD</b></p> <p>Moving parts can pinch, cut or amputate fingers and other body parts.</p> <ul style="list-style-type: none"> <li>• Keep clear of moving parts.</li> <li>• Do not operate equipment with protective guards or covers removed.</li> <li>• Pressurized equipment can start without warning. Before checking, moving, or servicing equipment, follow the <b>Pressure Relief Procedure</b> and disconnect all power sources.</li> </ul>
	<p><b>PERSONAL PROTECTIVE EQUIPMENT</b></p> <p>Wear appropriate protective equipment when in the work area to help prevent serious injury, including eye injury, hearing loss, inhalation of toxic fumes, and burns. This protective equipment includes but is not limited to:</p> <ul style="list-style-type: none"> <li>• Protective eyewear, and hearing protection.</li> <li>• Respirators, protective clothing, and gloves as recommended by the fluid and solvent manufacturer</li> </ul>

# Installation

## Component Identification

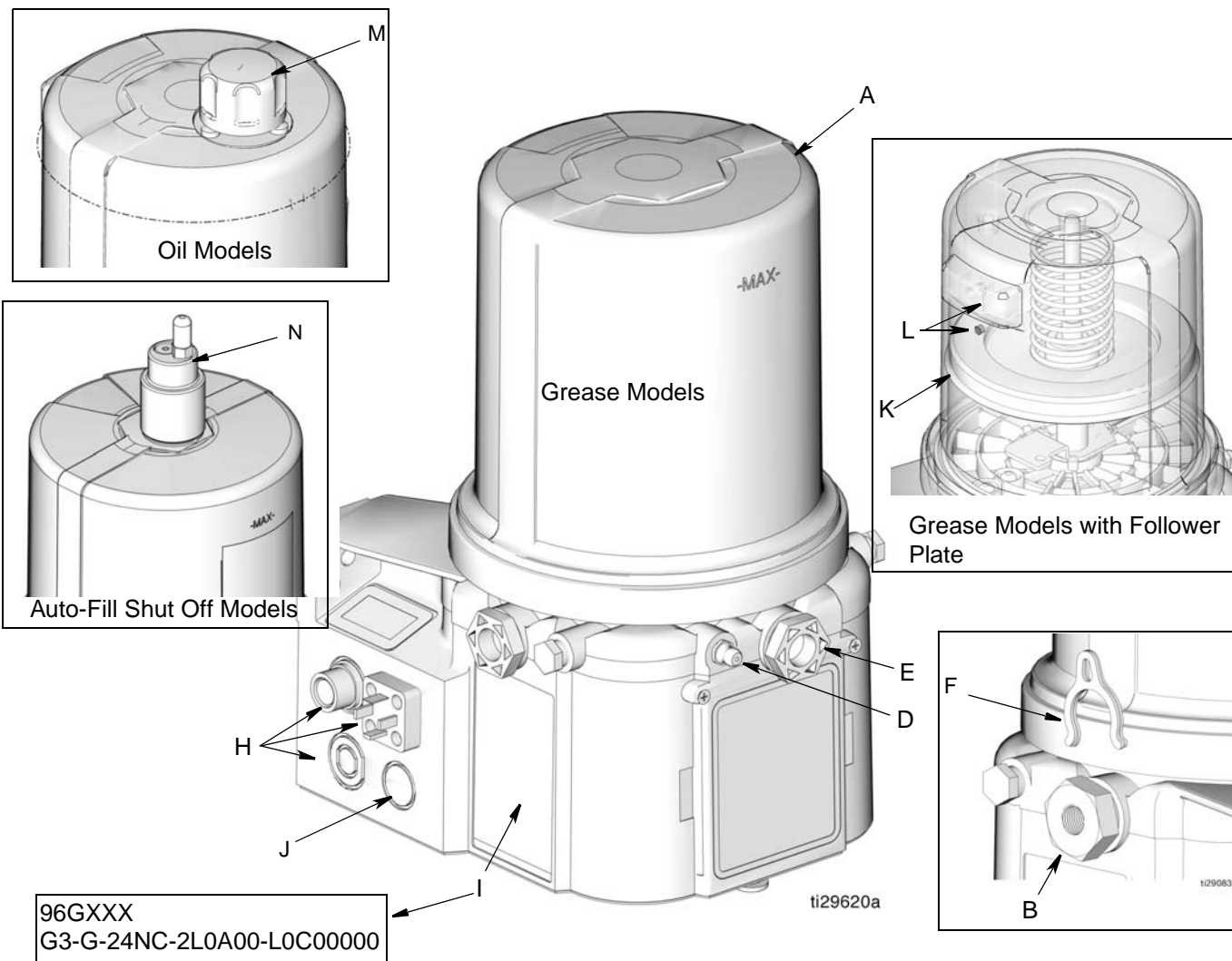

**FIG. 2**

**Key:**

- |   |   |
|---|---|
| <p>A Reservoir</p> <p>B Adjustable Pump Element (1 included. Can accommodate 3 total)</p> <p>C Pressure Relief Valve (Not included (not shown) / required for each outlet - Available from Graco. See Parts, page 32.)</p> <p>D Zerk Inlet Fill Fitting (1 included / grease models only)</p> <p>E Pump Outlet Plug (2 included)</p> <p>F Volume Control Spacers (2 included. More spacers = less output volume per stroke) (also see FIG. 18, page 19)</p> <p>G Fuse (DC models only - Not included, not shown. Available from Graco. See Parts, page 32.)</p> <p>H Power / Sensor Panel (both sides; only one side shown)</p> <p>I Part Number / Model Number example only shown, (see page 4, Understanding the Model Number, for details)</p> <p>J Power Cord (DIN shown)</p> | <p>K Follower Plate (grease models only / not available on all grease models)</p> <p>L Vent Hole for Follower Plate (grease models only / not available on all grease models)</p> <p>M Fill cap (oil models only)</p> <p>N Auto-Fill Shut Off</p> |
|---|---|

## Typical Installation

### Series Progressive Divider Valve

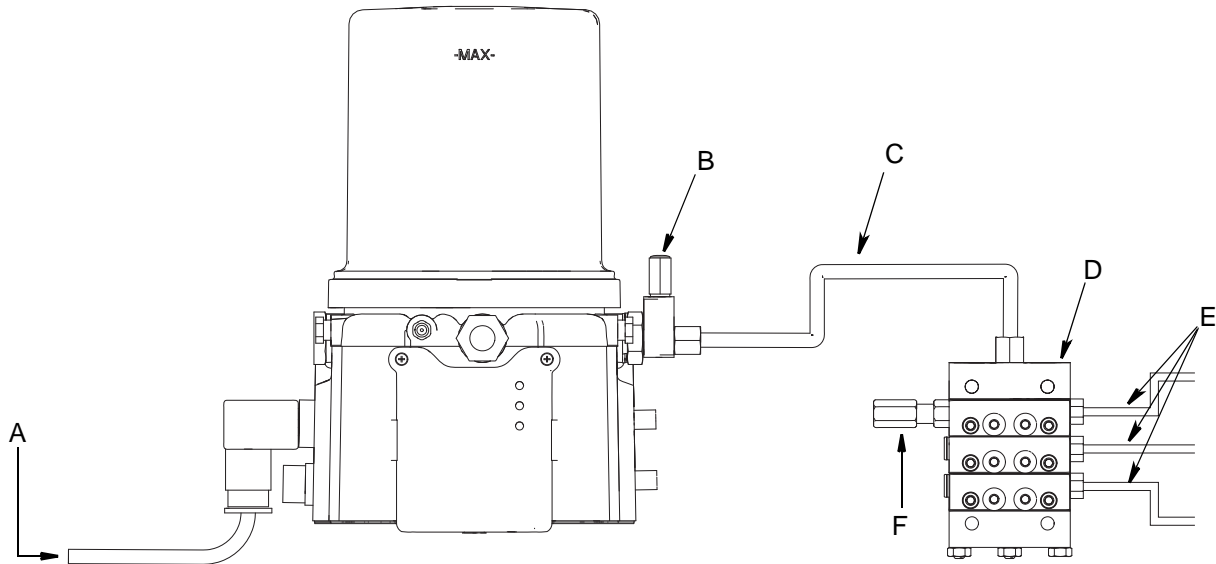

FIG. 3

### Injector Installations

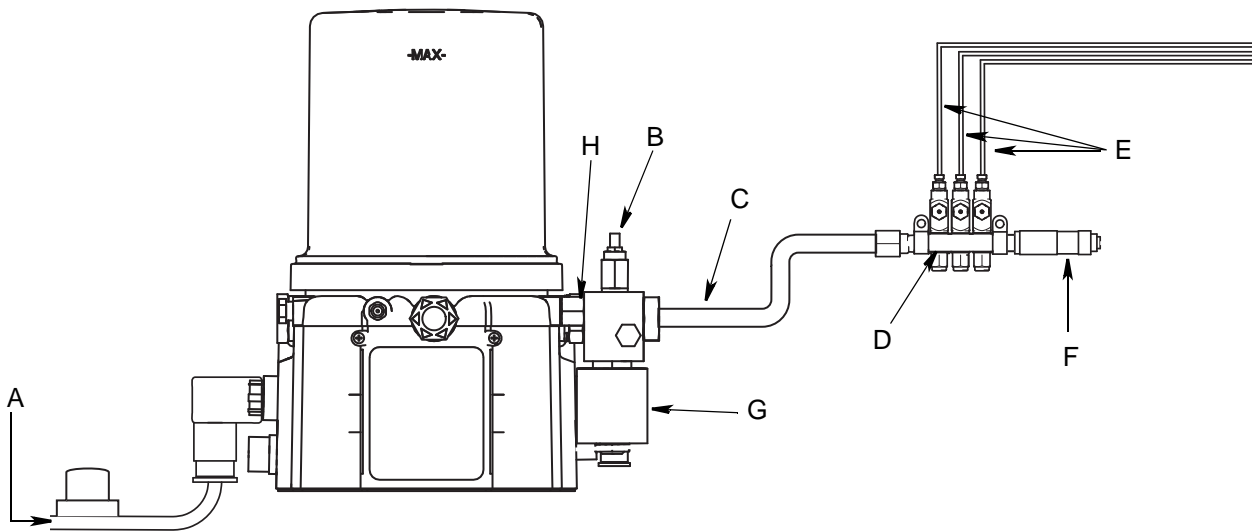

FIG. 4

#### Key

- |   |  |   |  |
|---|--|---|--|
| A | Connected to fused power source  | E | To lube points   |
| B | Pressure relief valve (Not included/ required for each outlet - user supplied. See Parts, page 32) | F | - Proximity Switch (Divider Installations)<br>- Pressure switch (Injector Installations) |
| C | Supply Hose (user supplied)  | G | Vent valve (Not included / available from Graco. See Parts, page 33.)                    |
| D | Series progressive divider valves (Divider Installations)<br>- Injectors (Injector Installations)  | H | Return to reservoir  |



## Typical Installation - With Remote Fill Manifold

The installation shown is only a guide for selecting and installing system components. Contact your Graco distributor for assistance in planning a system to suit your needs.

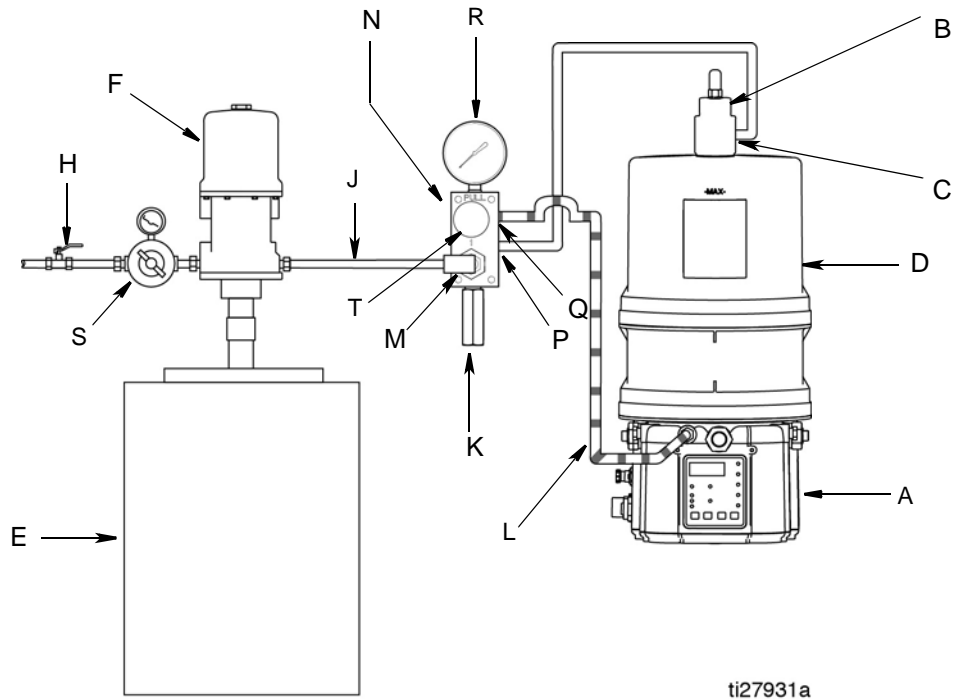

FIG. 5

### Key:

- A G3 Pump
- B Auto-Fill Shut Off Valve
- C Auto-Fill Inlet
- D G3 Reservoir
- E Remote Fill Reservoir
- F Remote Fill Pump
- G Supply Hose (user supplied)
- H Air Supply to Refill Pump
- J Supply Hose (user supplied)
- K Pressure Relief Valve
- L Drain Hose
- M Fill Coupler/Inlet (quick disconnect)
- N Fill Manifold❖
- P Fill Manifold Outlet
- Q Fill Manifold Vent Port
- R Pressure Gauge
- S Pressure Regulator and Gauge
- T Pressure Relief Knob

❖ To relieve the stall pressure in the fill line a fill manifold (N) **must** be installed in the system.

## Optional Installation - Without Remote Fill Manifold

The installation shown is only a guide for selecting and installing system components. Contact your Graco distributor for assistance in planning a system to suit your needs.

**NOTE:** The remote filling station pump stalls (dead-heads) when the reservoir is full. If the pump does not stall (dead-head) there is a leak in the system.

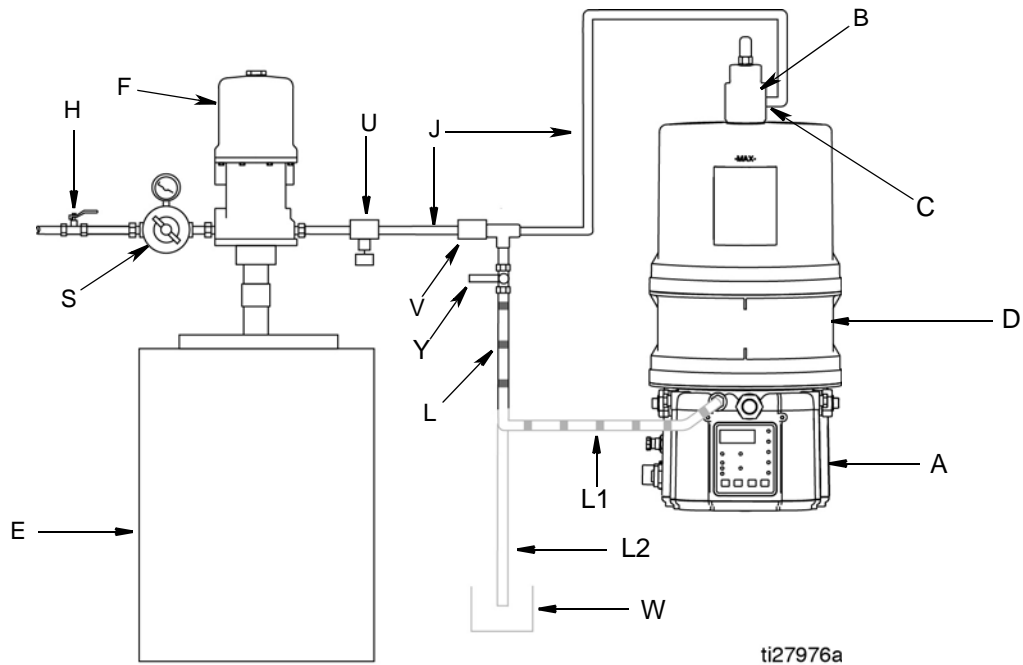

FIG. 6

**Key:**

- A G3 Pump
- B Auto-Fill Shut Off Valve
- C Auto-Fill Inlet
- D G3 Reservoir
- E Remote Fill Reservoir
- F Remote Fill Pump
- H Relief Valve
- J Supply Hose (user supplied)
- L Drain Tube
  - L1 Option - To reservoir
  - L2 Option - To overflow container
- S Pressure Regulator and Gauge
- U Pressure Relief Valve
- V Quick Disconnect
- W Overflow Container
- Y Supply Hose Pressure Relief Valve❖

❖ To relieve the stall pressure in the fill line a ball valve (Y) **must** be installed in the system.

## Choosing an Installation Location



### AUTOMATIC SYSTEM ACTIVATION HAZARD

If the system is equipped with has an automatic timer (user supplied) that activates the pump lubrication system when power is connected or when exiting the programming function, unexpected activation of the system could result in serious injury, including skin injection and amputation.

Before you install or remove the lubrication pump from the system, disconnect and isolate all power supplies and relieve all pressure.



- Select a location that will adequately support the weight of the G3 Pump and lubricant, as well as all plumbing and electrical connections.
- Refer to the mounting hole layouts provided in the Mounting Pattern section of this manual, page 35. No other installation configuration should be used.

- Use designated mounting holes and provided configurations only.
- Always mount the G3 oil models upright.
- If the G3 grease model is going to be operated in a tilted or inverted position for any period of time, you must use a model that includes a follower plate, otherwise the G3 must be mounted upright. Refer to your model number to confirm if a follower plate was installed on your pump. See page 4, Understanding the Model Number to identify this character in your model number.
- Use the three fasteners (included) to secure the G3 to the mounting surface.
- Some installations may require an additional reservoir support bracket. See Table below for bracket information

Part No	Description
571159	Reservoir bracket and strap
125910	L-Bracket for pump
127665	USP to G-Series mounting bracket

# System Configuration and Wiring

## Grounding

				
<p>The equipment must be grounded to reduce the risk of static sparking and electric shock. Electric or static sparking can cause fumes to ignite or explode. Improper grounding can cause electric shock. Grounding provides an escape wire for the electric current.</p> <p>Improper installation of the grounding conductor may result in a risk of electric shock. This product must be installed by a qualified electrician in compliance with all state and local codes and regulations.</p>				

If the product is permanently connected:

- it must be installed by a qualified electrician or serviceman.
- it must be connected to a grounded, permanent wiring system.

If an attachment plug is required in the end use application:

- it must be rated for the product electrical specifications.
- it must be an approved, 3-wire grounding type attachment plug.
- it must be plugged into an outlet that is properly installed and grounded in accordance with all local codes and ordinances.
- when repair or replacement of the power cord or plug is required, do not connect the grounding wire to either flat blade terminal.

## Fuses

<b>NOTICE</b>
<p>Fuses (user supplied) are required on all DC models. To avoid equipment damage:</p> <ul style="list-style-type: none"> <li>• Never operate G3 Pump DC models without a fuse installed.</li> <li>• A fuse of the correct voltage must be installed in line with the power entry to the system.</li> </ul>

Fuse Kits are available from Graco. The following Table identifies the correct fuse to use for your input voltage and the corresponding Graco Kit number.



Input Voltage	Fuse Value	Graco Kit No.
12 VDC	7.5 A	571039
24 VDC	4 A	571040

## Recommendations for Using Pump in Harsh Environments

- Use pump with CPC style power cable.
- If using a DIN style power or alarm harness with a right angle mating connector, make sure the connector does not exit the unit in the UP direction.
- Use a corrosion preventative electrical grease on all contacts.

# Wiring and Installation Diagrams

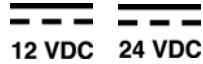
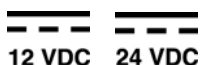
The following Table identifies the wiring and installation diagrams for the cable included with the pump provided in this manual.

Diagram	Symbol	Page
Power DIN AC		13
Power DIN DC		14
Power CPC DC		14
Low Level Outputs		15



## Power DIN AC - 15 foot

### Pin and Related Wire Color (Fig. 7)

Pin	Pin Name	Color
1	Line	Black
2	Neutral	White
3	Not Used	Not Used
	Ground	Green

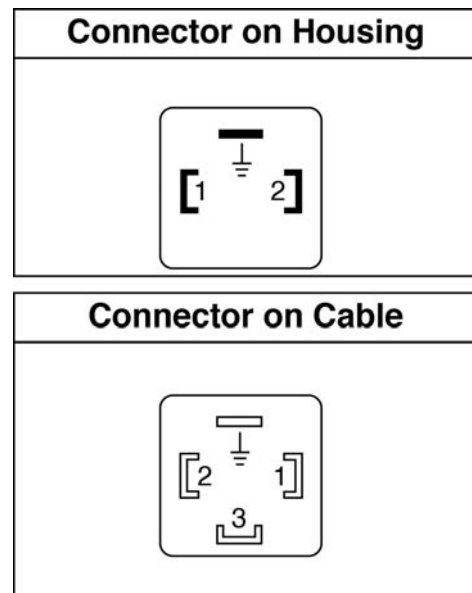

ti27630a

FIG. 7

  **Power DIN DC - 15 foot**

  **Power CPC DC - 15 foot**

**Pin and Related Wire Color (Fig. 8)**

Pin	Pin Name	Color
1	-VDC	Black
2	+VDC	White
3	Not Used	Not Used
	Not Used	Green

**Pin and Related Wire Color (Fig. 9)**

Pin	Pin Name	Color
1	Not Used	Not Used
2	-VDC	Black
3	+VDC	White
4	Not Used	Not Used
5	Not Used	Not Used
6	Not Used	Not Used
7	Not Used	Green

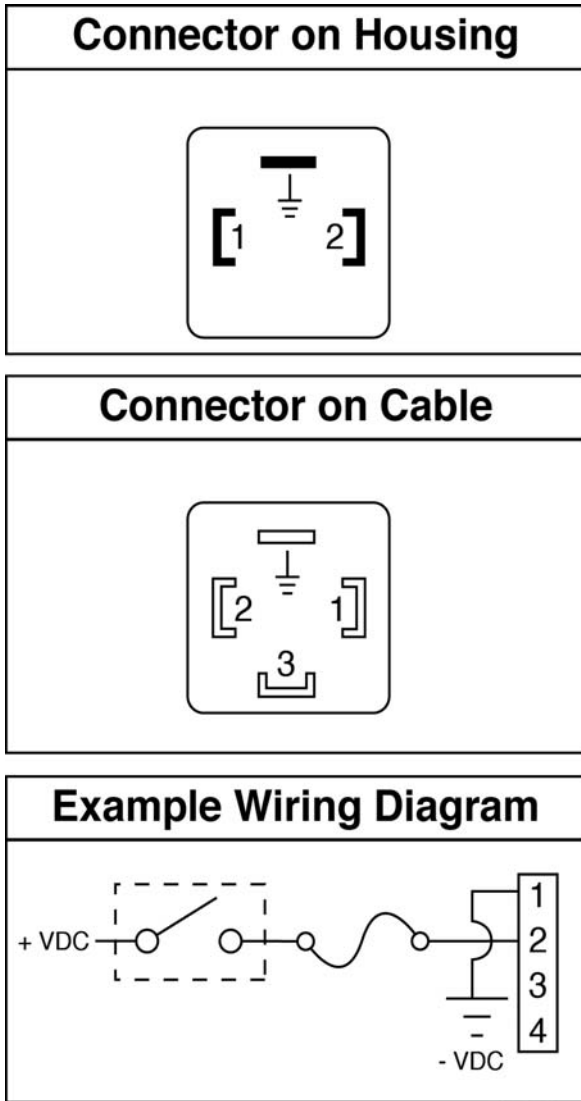

ti27631a

**FIG. 8**

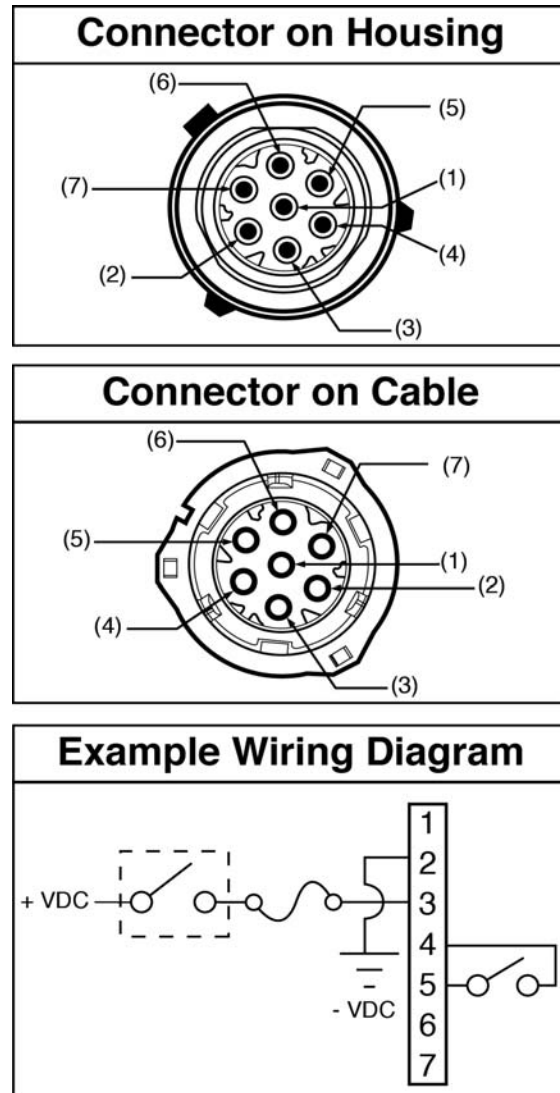

ti29557a

**FIG. 9**

**12 VDC 24 VDC Power CPC DC - With Low Level**

**Pin and Related Wire Color (FIG. 10)**

Pin	Pin Name	Color
1	Not Used	Not Used
2	-VDC	Black
3	+VDC	Red
4	LL N.O.	White
5	LL COM	Orange
6	Not Used	Not Used
7	Not Used	Green

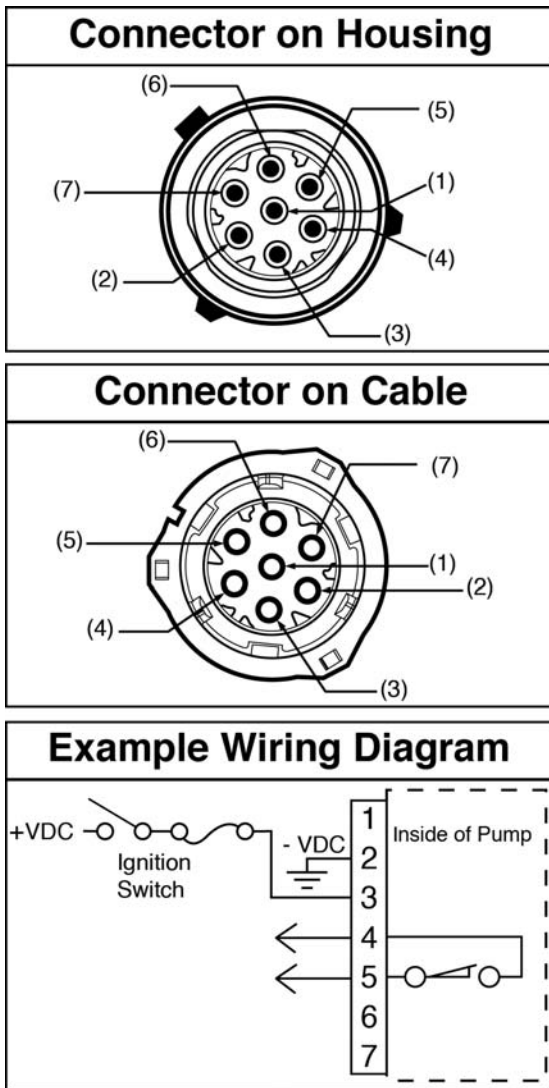

**FIG. 10**

ti29705a

**Low Level Outputs**

See Low Level Output Option, page 25 for functional description. See Technical Data, page 34 for ratings.

**Pins (FIG. 11)**

Pin	Pin Name
1	Not Used
2	Not Used
3	LL N.O.
4	LL COM

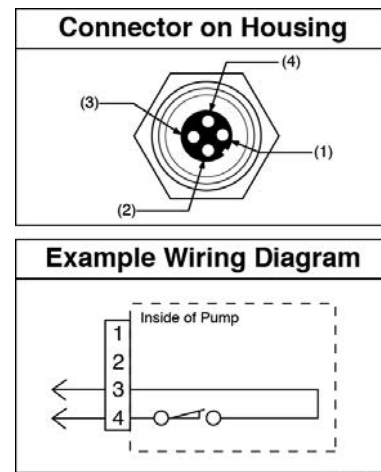

**FIG. 11**

**Pins (FIG. 12)**

Pin	Pin Name
1	LL N.O.
2	Not Used
3	LL COM
4	Not Used

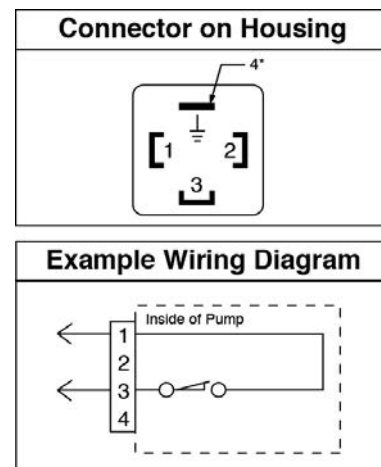
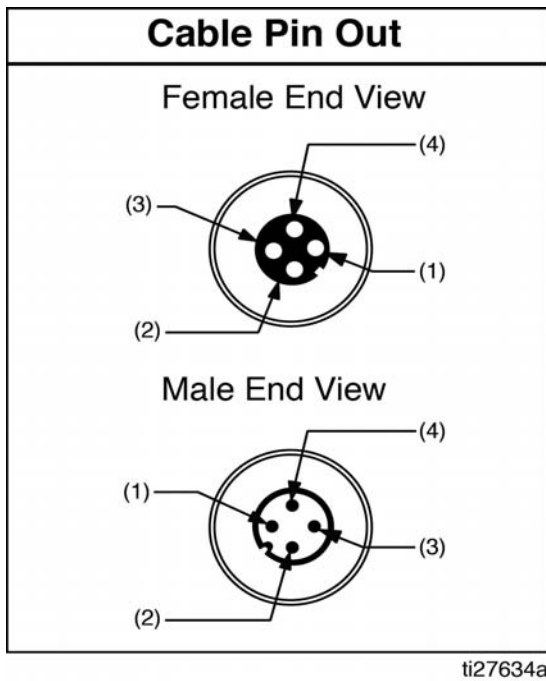

**FIG. 12**

**Part No. 124333: Cable Pin Out (M12)**

**Wire Colors (FIG. 13)**

Item No.	Color
1	Brown
2	White
3	Blue
4	Black

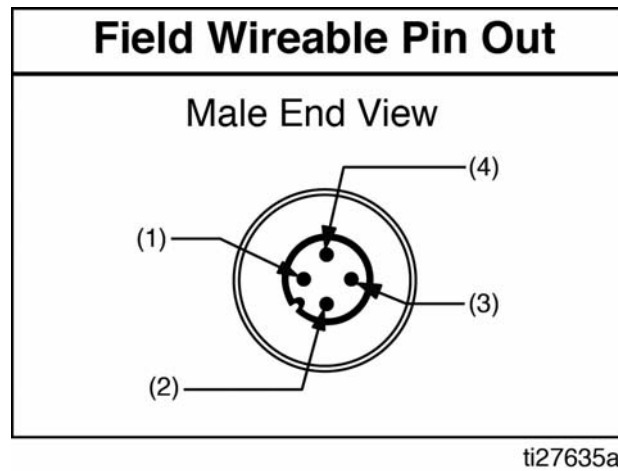

**FIG. 13**

**Part No. 124300: Field Wireable Pin Out (M12)**

**Wire Colors (FIG. 14)**

Item No.	Color
1	Brown
2	White
3	Blue
4	Black



**FIG. 14**



**Part No. 124594: 4 Pin Eurofast Male Field Wireable Connector (FIG. 15)**

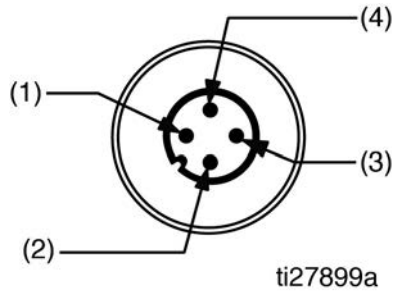

**FIG. 15**

---

**Part No. 124595: 5 Pin Eurofast Male Field Wireable Connector (FIG. 16)**

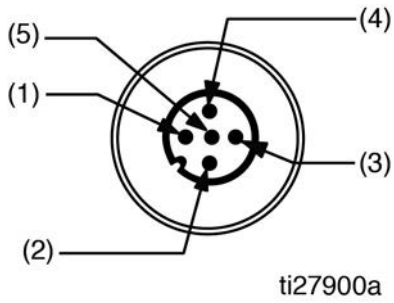

**FIG. 16**

---

# Setup

## Pressure Relief



Follow the Pressure Relief Procedure whenever you see this symbol.



This equipment stays pressurized until pressure is manually relieved. To help prevent serious injury from pressurized fluid, such as skin injection, splashing fluid and moving parts, follow the Pressure Relief Procedure when you stop dispensing and before cleaning, checking, or servicing the equipment.

**Relieve pressure** in system using two wrenches working in opposite directions on pump element and pump element fitting to ***slowly loosen fitting only*** until fitting is loose and no more lubricant or air is leaking from fitting.

**NOTE:** When loosening pump element fitting, do NOT loosen **pump element**. Loosening pump element will change the output volume.

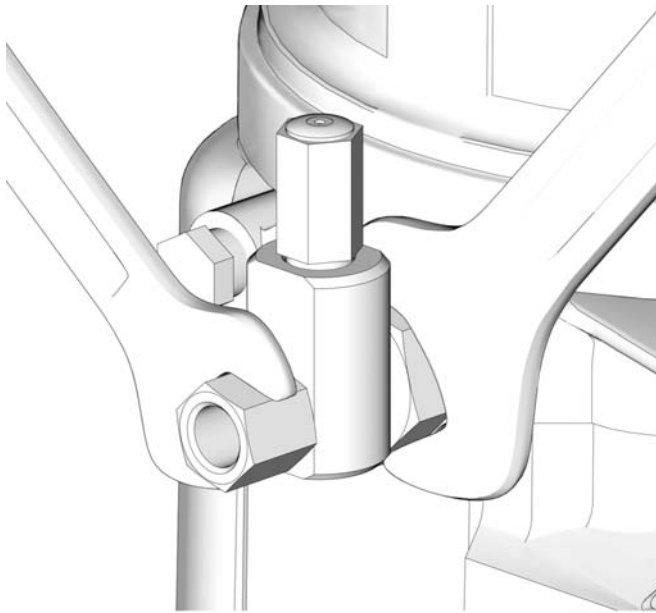

ti29082a

FIG. 17

## Connecting to Auxiliary Fittings

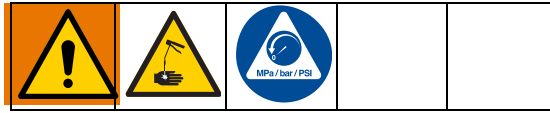

### NOTICE

Do not attach unsupported equipment to auxiliary fittings such as fill ports and pump element. Attaching unsupported equipment to these fitting can result in irreparable housing damage.

- Always use two wrenches working in opposite directions when connecting anything to pump element or auxiliary fittings. See FIG. 17 for an example.
- Torque pump element fittings to 50 in. lbs (5.6 N•m).
- When connecting pump element into housing torque to 50 in. lbs (5.6 N•m).

## Pressure Relief Valves



To prevent over-pressurization, which can result in equipment rupture and serious injury, a pressure relief valve appropriate for the lubrication system must be installed close to every pump outlet to alleviate unintended pressure rises in the system and protect the G3 pump from damage.

- Only use a pressure relief valve that is rated for no more than the working pressure of any component installed in the system. See Technical Data, page 30.
- Install a pressure relief valve close to every pump outlet; before any auxiliary fitting.

**NOTE:** A pressure relief valve can be purchased from Graco. See Parts, page 32.

# Setting Pump Outlet Volume



**NOTE:**

- Before making any adjustments to pump volume, **Relieve Pressure** following procedure on page 18.
  - Only use Graco supplied spacers to control output volume.
  - It may be necessary to repeat this outlet volume setup procedure after the pump is operating to re-adjust the volume of dispensed fluids.
1. Use a wrench to turn pump element counter-clockwise to loosen. Do not remove entire pump element. Only back pump element out enough to allow spacer to be slid on or off (FIG. 18).

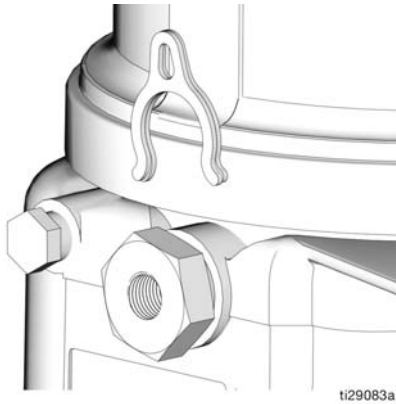

**FIG. 18**

2. If needed, remove or insert spacers to achieve required pump output volume. A tool may be needed to facilitate removal.

Pump volume control is set using either no (0) spacers, 1 or 2 spacers (FIG. 18).

Do not use more than 2 spacers to adjust output volume.

No. Spacers	Output Volume / Minute	
	cubic inches	cubic cm
2	0.12	2
1	0.18	3
0	0.25	4

3. Tighten pump element fitting. Torque fitting to 50 in. lbs (5.6 N•m).
- The amount of dispensed volume can vary depending on external conditions such as lubricant temperature and back pressure from downstream connections.
  - Use of these volume adjustment in conjunction with setting the ON time of the pump will allow for control of the output volume.
  - Use these volume adjustments as a starting point and adjust as necessary to ensure desired lubrication dispense.

## Loading Grease

To ensure optimal performance from the G3:

- Only use NLGI #000 - #2 greases appropriate for your application, automatic dispensing, and the temperature. Consult with machine and lube manufacturer for details.
- The reservoir can be filled using a hand operated pump, pneumatic pump or electric transfer pump.
- Do not overfill.
- Do not operate G3 without reservoir attached.

<b>NOTICE</b>	
• Always clean fitting (D) (FIG. 19) with a clean dry cloth prior to filling reservoir. Dirt and/or debris can damage pump and/or lubrication system.	
• Care must be used when filling the reservoir using a pneumatic or electric transfer pump to not pressurize and break the reservoir.	

**Models without a follower plate:**

1. Connect fill hose to inlet fitting (FIG. 19).

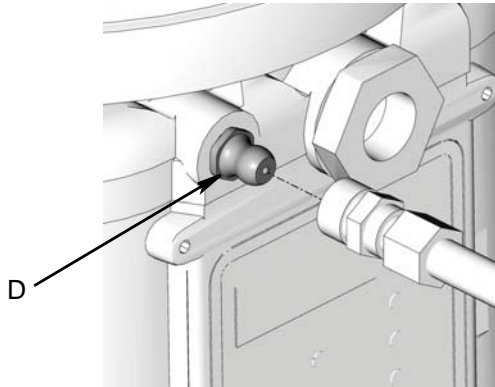

**FIG. 19**

2. For higher viscosity fluids, start pump to rotate stirring paddle during fill to prevent air pockets from forming in grease. Do not exceed 30 minutes run time.

For models using an external controller, start pump operation per your controller specifications.

3. Fill reservoir with NLGI grease.

**NOTE:** Vent port, located in rear of reservoir, should not be used as an overfill port/indicator.

4. Remove fill hose.

**Models with a follower plate:**

1. Connect fill hose to inlet fitting (FIG. 19).
2. For higher viscosity fluids, start pump to rotate stirring paddle during fill to prevent air pockets from forming in grease. Do not exceed 30 minutes run time.

For models using an external controller, start pump operation per your controller specifications.

3. Fill reservoir with grease until seal of follower plate breaches the vent hole (FIG. 20) and the majority of air is expelled from the reservoir.

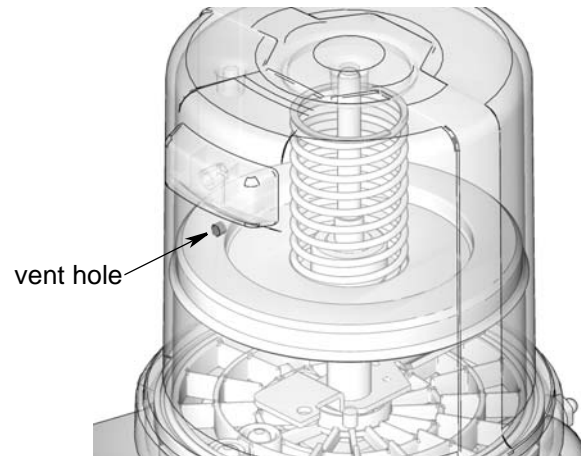

**FIG. 20**

**NOTE:** Vent port, located in rear of reservoir, should not be used as an overfill port/indicator.

4. Remove fill hose.

**Changing Greases**

When changing greases, always use compatible fluids or greases.

5. Turn off the air supply (H) to refill pump (F).
6. Relieve remote filling station pump pressure using the following Remote Filling Station Pressure Relief procedure.

## Auto-Fill Shut Off

### Loading Grease

To ensure optimal performance from the G3:

- Only use NLGI #000 - #2 greases appropriate for your application, automatic dispensing, and the temperature. Consult with machine and lube manufacturer for details.
- Do not overfill.
- Do not operate G3 without reservoir attached.

#### NOTICE

Care must be used when filling the reservoir using a pneumatic or electric transfer pump to not pressurize and break the reservoir.

### Changing Greases

When changing greases, always use compatible fluids or greases.

The Auto-Fill Shut Off is used for refilling the G3 reservoir in an automatic lubrication system. As fluid is added to the reservoir, it pushes the plate valve up to the top of the reservoir. The plate valve then pushes the valve pin and closes the inlet fluid path.

When the fluid refilling path closes, the refilling line pressurizes and brings the refilling pump to a pressurized stall condition.

**NOTE:** The operator must monitor system while filling the reservoir to prevent overfilling.



The remote filling station pump stalls (dead-heads) when the reservoir is full, causing the supply system pressure to rise to the maximum output pressure of the filling station pump. To help prevent equipment damage or serious injury caused by pressurized fluid, such as skin injection or injury from splashing fluid, always use a remote filling station pump with a maximum output pressure of 5100 psi (35.1 MPa, 351.6 bar) and use supply hoses with a minimum pressure rating of 5100 psi (35.1 MPa, 351.6 bar).



#### COMPONENT RUPTURE HAZARD

The maximum working pressure of each component in the system may not be the same. To reduce the risk of over-pressurizing any component in the system, be sure you know the maximum working pressure of each component. **Never** exceed the maximum working pressure of the lowest rated component in the system. Over-pressurizing any component can result in rupture, fire, explosion, property damage and serious injury.

Regulate input pressure to the remote fill pump so that no fluid line, component or accessory is overpressurized.

### Remote Fill with Remote Fill Manifold

The reference letters used in the following instructions refer to the Typical Installation diagrams starting on pages 8.

The fill valve is used to relieve pressure in the refill line and to reset the Auto Fill Shut Off. See Fill Valve instruction manual 333393. Graco fill valve, part no. 77X542 is available. Contact your local Graco distributor.

1. Pull out and hold the Pressure Relief Knob (T) long enough to relieve line pressure between Fill Manifold (N) and Auto-Fill Shut Off Valve (B).
2. Verify the Auto-Fill Shut Off (B) pin is down, indicating it is reset (FIG. 21).

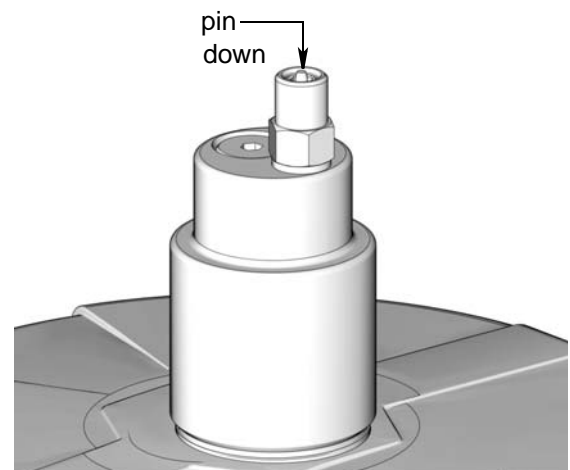

FIG. 21

ti28218a

3. Remove yellow Dust Cover from Fill Coupler (M).
4. Connect Supply Hose (J) between the Remote Filling Station Pump (F) and Fill Coupler port marked with an "I".
5. Start Remote Filling Station Pump (F).
6. When the G3 Reservoir (D) is filled:
  - the Remote Filling Station Pump (F) stalls (dead-heads),
  - the Auto-Fill Shut Off (B) pin pops up as shown in FIG. 22,
  - the Pressure Gauge (R) rises to the fill pump's set pressure.

**NOTE:** If the pump does not stall (dead-head) there is a leak in the system.

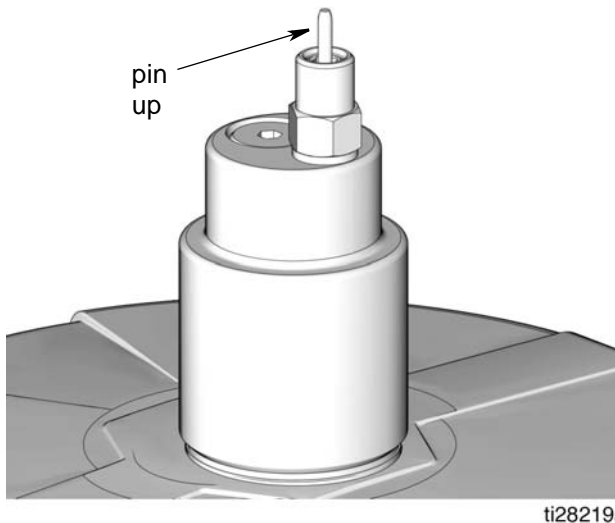

FIG. 22

7. Turn off the Remote Filling Station Pump (F).
8. Pull out and hold the Pressure Relief Knob (T) long enough to relieve line pressure between Fill Manifold (N) and Auto-Fill Shut Off Valve (B) and between Remote Filling Station Pump (F) and Fill Manifold (N).

**NOTE:** The length of time it takes to vent varies depending on the system design and installation. In some installations it may be necessary to repeat Step 8 to ensure pressure is relieved.

9. Disconnect Supply Hose (J) at Fill Coupler (M).
10. Replace yellow Dust Cover over Fill Coupler (M).

## Remote Fill without Remote Fill Manifold

The reference letters used in the following instructions refer to the Typical Installation diagrams starting on pages 8.

1. A supply hose pressure relief valve (Y) and overflow container (W) (for collecting excess fluid that drains during pressure relief) **must** be installed in an easily accessible location between the remote filling station pump (F) and the Auto-Fill Shut Off (B). This pressure relief valve is used to relieve pressure in the refill line and to reset the Auto-Fill Shut Off. See Typical Installation, starting on page 9.

A Pressure Relief Kit: 247902 is available from Graco. Contact your distributor or Graco Customer Service for additional information about this kit.

2. Connect Supply Hose (J) at Quick Connect (V).
3. Turn on remote filling station pump (F) and fill the G3 reservoir (D) until the indicator pin on the Auto-Fill Valve pushes up as shown in FIG. 23. The pressure in the refill pump (F) builds and the pump stalls.

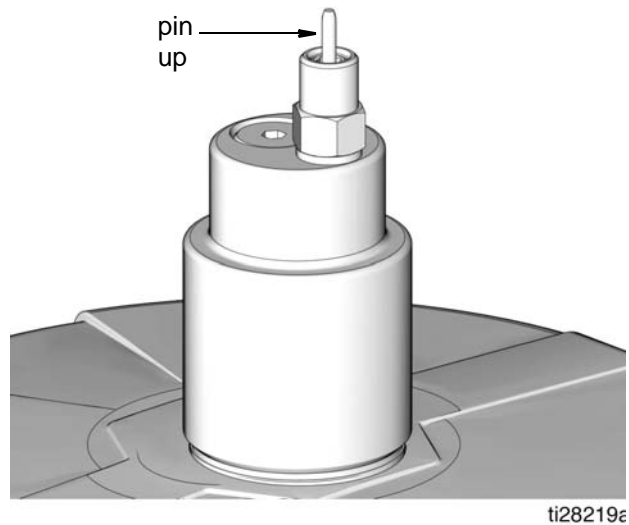

FIG. 23

4. Turn off the air supply (H) to pump (F).
5. Relieve remote filling station pump pressure using the following Remote Filling Station Pressure Relief procedure:

## Remote Filling Station Pressure Relief

The reference letters used in the following instructions refer to the Typical Installation diagrams starting on page 8.



The following Pressure Relief Procedure is only used with the Auto-Fill Shut Off Valve to relieve remote filling station and lubricant supply line pressure.

<p>This equipment stays pressurized until pressure is manually relieved. To help prevent serious injury from pressurized fluid, such as skin injection, splashing fluid and moving parts, follow the Pressure Relief Procedure when you stop dispensing and before cleaning, checking, or servicing the equipment.</p>				

- a. To relieve pressure between the Refill Pump (F) and Auto-Fill Shut Off (B), open ball valve (bv) (FIG. 24). Pressure will be released and excess fluid will drain out of the drain tube (L) and into the lubrication overflow container (W).

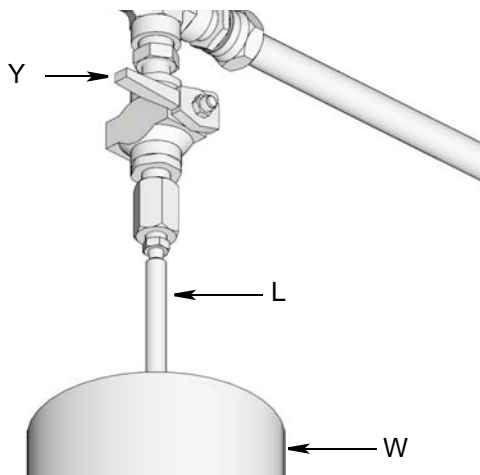
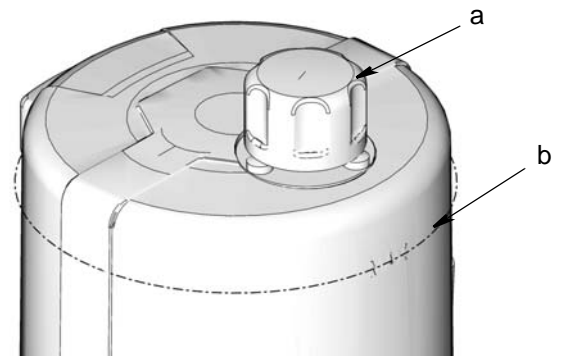

**FIG. 24:**

- b. Close supply hose pressure relief valve (Y) when all pressure has been relieved.
6. Disconnect the supply hose (J) from Quick Connect (V).

## Filling Oil Unit

- Only use oil appropriate for your application, automatic dispensing, and the equipment's operating temperature. Consult with machine and lube manufacturer for details.
- The reservoir can be filled using a hand operated pump, pneumatic pump or electric transfer pump.
- Do not overfill (FIG. 25).
- Do not operate G3 without reservoir attached.
- Only use oils with viscosity at least 40 cSt.



**FIG. 25**

1. Remove fill cap (a).
2. Pour oil into reservoir to max fill line (b).
3. Replace fill cap. Hand tighten cap, securely.

## Priming

**NOTE:** It is not necessary to prime pump every time pump is filled with lubricant.

Pump only requires priming the first time it is used or if it is allowed to run dry.

1. Loosen pump element fitting (FIG. 26).

**NOTE:** When loosening pump element fitting, do NOT loosen **pump element**. Loosening pump element will change the output volume

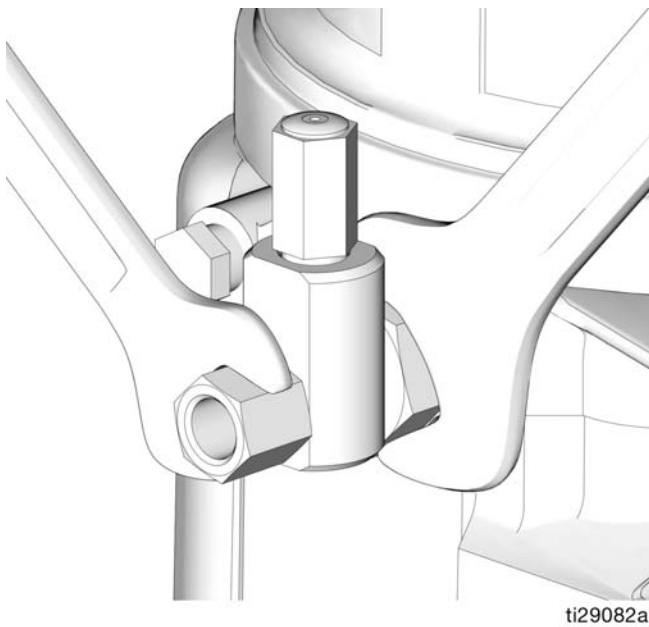

**FIG. 26**

2. Only run pump until air-free lubricant is dispensed out of element fitting (FIG. 27).

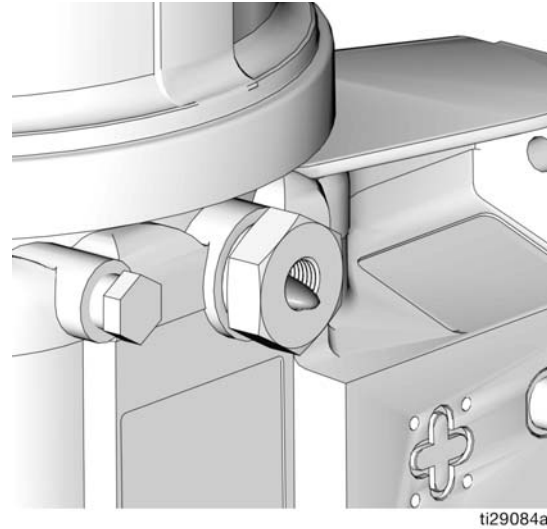

**FIG. 27**

3. Tighten pump element fitting using two wrenches working in opposite directions (FIG. 26).



# Pump Operation

The G3 Pump can be controlled using an external, user supplied, power source and controller.

Refer to the Typical Installation diagrams starting on page 8 for correct location of the required pump ground wire and fuses.

## NOTE:

- When using an external power source and controller, Pump ON (Run) Time should be set for no longer than 30 minutes.
- In most cases, Pump OFF (Rest) Time should be twice as long as Pump ON (Run) time. If alternative ON / OFF times are required, contact Graco Customer Service for assistance.

## Low Level Output Option

Some G3 pumps without controllers include a Low Level Output Option. It can be configured with an M12 connector in code location “G” or with a DIN connector in code location “K”. (See Understanding the Model Number, page 4.) The low level signal is monitored across PINS 3 and 4. For PIN 3 and 4 locations and wiring information the Low Level Outputs diagram, page 15.

**NOTE:** A low level warning is triggered when the controller detects PINS 3 and 4 have momentarily closed.

## Grease Pumps

When the grease level has reached a low warning level, PINS 3 and 4 momentarily close (1 time per paddle revolution) sending the signal that the fluid has reached a low level to the controller.

To ensure that a low level condition has been met, 3 or more low level triggers must be detected within 1 minute or less.

See FIG. 28 for an illustration of a typical Low Level Output response to low grease level.

**Typical Low Level Output Response with Low Level Fluid in Grease Models**

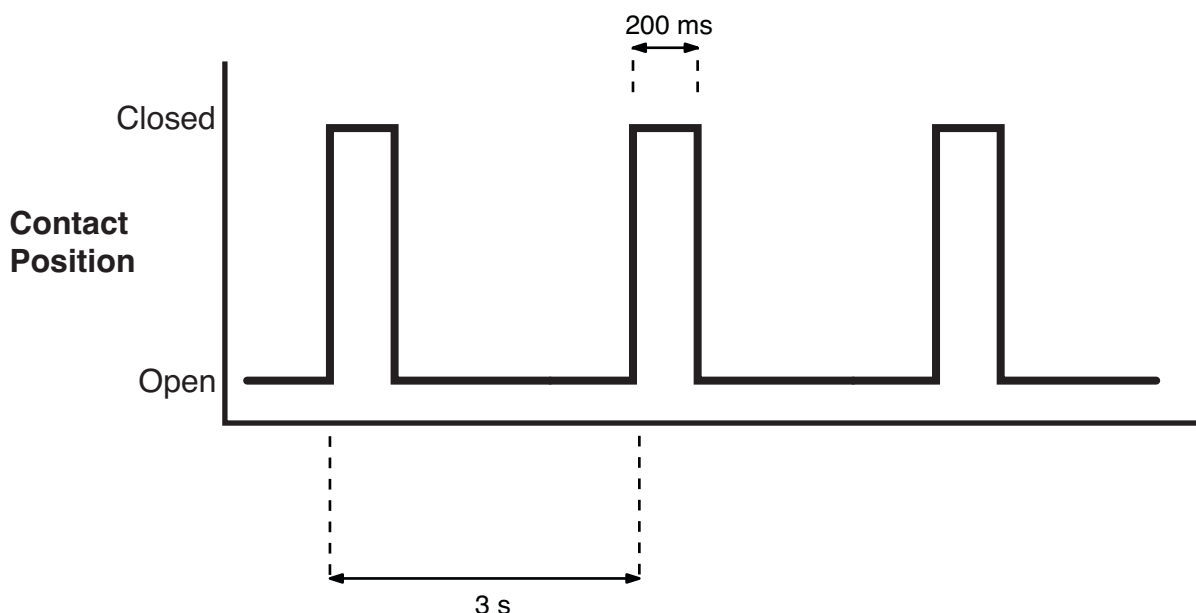

**FIG. 28**

**Oil Pumps**

When the oil level has reached a low warning level, PINS 3 and 4 close, sending the signal to the controller that the fluid has reached a low level.

To ensure that a low level condition has been met, the low level trigger must be detected for 10 continuous seconds.

See FIG. 29 for an illustration of a typical Low Level Output response to low oil level.

*Typical Low Level Output Response with Low Level Fluid in Oil Models*

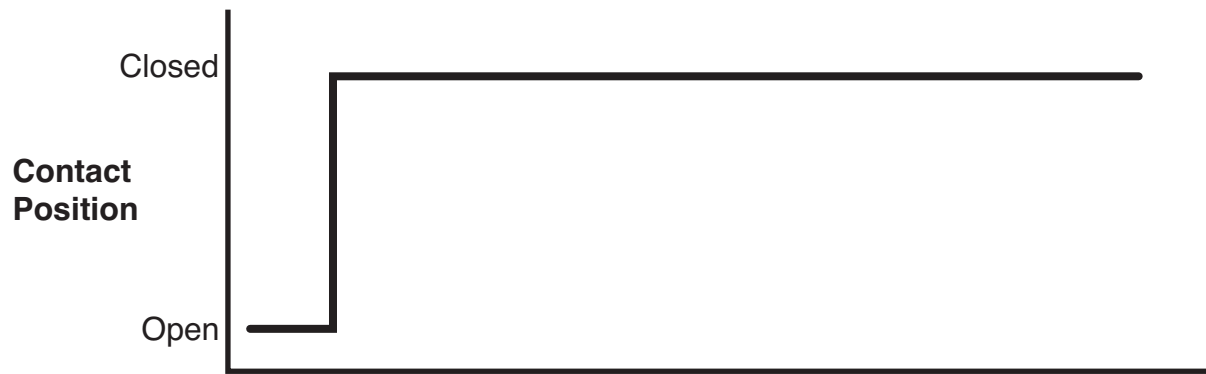

**FIG. 29**

---

# Troubleshooting

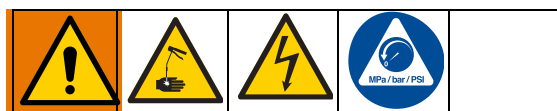

Problem	Cause	Solution
Unit does not power on	Incorrect/loose wiring	Refer to Installation instructions, page 7.
Unit does not power on (DC models only)	Tripped external fuse due to internal component failure	Contact Graco Customer Service.
	Tripped external fuse due to pumping non-cold weather lubricant in cold weather -13°F (-25°C)	Replace lubricant with pumpable lubricant, rated for environmental conditions and application.  Replace fuse.
Unit does not power on (AC models only)	Tripped internal power supply fuse due to power supply failure	Contact Graco Customer Service.
Lubricant leaks past seal located on the bottom of the reservoir	Reservoir retaining tabs are cracked or broken	Replace reservoir.
	Reservoir is being pressurized during filling	Ensure vent hole is not plugged.  If problem persists, contact Graco Customer Service or your local Graco distributor for assistance.
Unit not pumping during ON cycle, but external controller functions	Failed motor	Replace unit.
Follower plate is not going down	Air is trapped in the reservoir between the follower plate and lubricant	Add grease following Loading Grease instructions, page 19. Ensure air is purged.
Pump takes several minutes before it begins pumping at the highest pump volume setting (no stroke adjust spacers installed)	Pumping non-cold weather lubricant in cold weather -13°F (-25°C)	Add 1 stroke adjust spacer and adjust lube cycle time to accommodate the difference in pump volume per stroke.
In an Injector System without sensor feedback, unit does not vent properly	Vent valve time needs to be configured	Adjust external vent valve control time.
After wiring and installing equipment, pump is not working	Pump wired backwards	Rewire pump. See wiring and installation diagrams, page 13

# Maintenance

<b>Frequency</b>	<b>Component</b>	<b>Required Maintenance</b>
Daily and at refill	Fill Fittings	Keep all fittings clean using a clean dry cloth. Dirt and/or debris can damage pump and/or lubrication system.
Daily	G3 Pump Unit and Reservoir	Keep pump unit and reservoir clean using a clean dry cloth.
Monthly	External Wiring Harness	Verify external harnesses are secure.

# Parts - 2 Liter Models

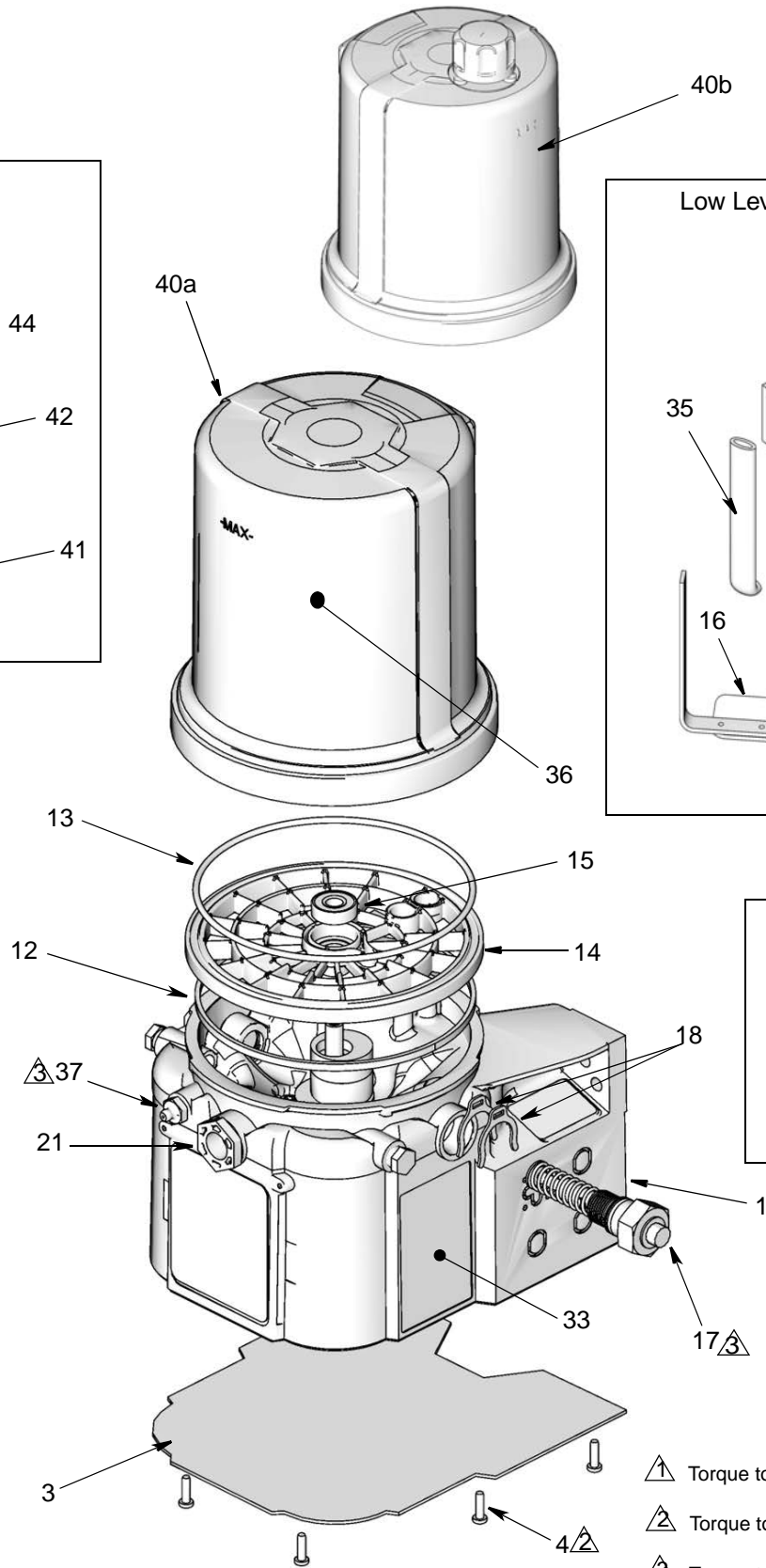
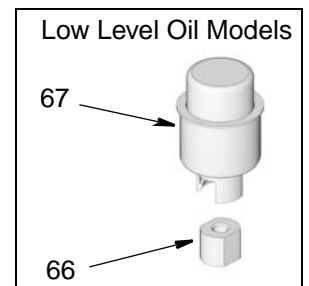
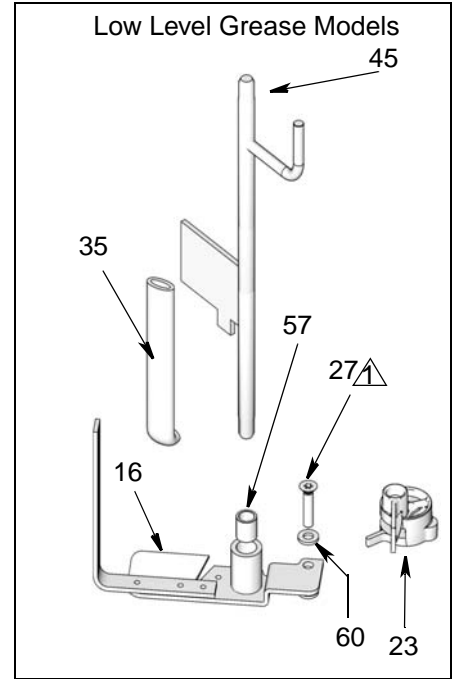
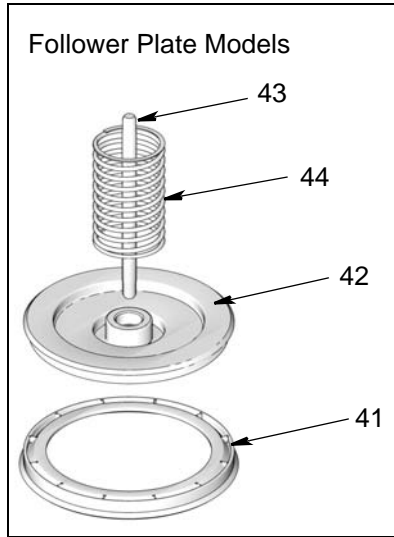

- Torque to 4 in. lbs (0.45 N.m)
- Torque to 30 in. lbs (3.4 N.m)
- Torque to 50 in. lbs (5.6 N.m)



# Parts

Ref	Part	Description	Qty
1		BASE, three pump housing	1
3	278142	COVER, bottom, with seal	1
4	115477	SCREW, mach, torx pan hd	9
12	127079	RECT-RING, included in kit 571042, 571069, 571179	1
13	124396	O-RING, 258, included in Kit 571042, 571044, 571045, 571069, 571179	2
14		PLATE, ricer	1
15		BEARING, ball	1
16		PADDLE, stirring, 2 Liter models without follower plate, included in Kit 571044,	1
		PADDLE, stirring, 4 Liter or larger models without follower plate	1
		PADDLE, stirring, 2 Liter models with follower plate, included in Kit 571045	1
		PADDLE, stirring, 4 Liter and larger models with follower plate	1
17		PUMP, element, included in Kit 571041	1
18	16F368	SPACER, stroke adjust, included in Kit 571041	2
21	278296	PLUG, pump, 3/4-16	2
23❖	278136	PADDLE, low level	1
27	123025	SCREW, M6	1
33▲	16A579	LABEL, safety	1
35		WIPER, stirring, models without follower plate, included in Kit 571044	1
		WIPER, stirring, models with follower plate, included in Kit 571045	1
36		LABEL, brand	1
37	123741	FITTING, zerk, grease, not included on oil models	1
40a	24E984	RESERVOIR, 2 Liter, grease, included in Kit 571042, 571069	1
40b	16G021	RESERVOIR, 2 Liter, oil, included in Kit 571179	1

Ref	Part	Description	Qty
40a	24B702	RESERVOIR, 4 Liter, grease, included in Kit 571183	1
40b	16G020	RESERVOIR, 4 Liter, oil, included in kit 571182	1
40c	17F484	RESERVOIR, 4 Liter, G3 AF50	1
41	278139	SEAL, follower plate, 2 Liter models	1
	16F472	SEAL, follower plate, 4 Liter models	2
42		PLATE, follower	1
43		ROD, follower plate	1
44		SPRING, compression	1
45†	24D838	BAFFLE, low level, 2 Liter	1
	24E246	BAFFLE, low level, 4 Liter	1
	24F836	BAFFLE, low level, 8 Liter	1
	24F923	BAFFLE, low level, 12 Liter	1
	24F924	BAFFLE, low level, 16 Liter	1
	24F836	BAFFLE, low level, 8 Liter, AF50	1
57	117156	BEARING, sleeve	1
58▲	196548	LABEL	1
60	16D984	WASHER, low level models	2
61	278135	RESERVOIR, mid-section (see quantity by size / model below)	
		8 Liter models	1
		12 Liter models	2
		16 Liter models	3
62	278134	ADAPTER, reservoir, 4 Liter models and larger	1
66		NUT, oil	1
67	24N806	FLOAT, oil models	1
72		PLATE, baffle, low level	1
73		SCREW, machine	2

Ref	Part	Description	Qty
74		SPRING, plate, valve, reset	1
81		VALVE, AFSSO	1
82		BOLT, mounting	1
83		PACKING, o-ring	1
84		PACKING, o-ring	1
85		SEAL, upper, reservoir	1
87		SEAL, lower, reservoir	1
88		SPACER, seal, base	1
89		PLATE, valve	1
200	127783	CABLE, 15 ft (4.5 m), SOOW w/7pos, 3 pin, 90 deg (See Wiring Diagram, page 14)	1
	16U790	CABLE, DIN, to flying leads (See Wiring Diagram, page 13)	1
201	124300	CABLE, M12, 15 ft., 4 wire, straight male to flying leads (See Wiring Diagram, page 16)	1
	124333	CABLE, M12, 15 ft., 4 wire, straight male to female (See Wiring Diagram, page 16)	1
202	124301	CONNECTOR, Eurofast, fem, straight, 4 Pin	1
	124594	CONNECTOR, Eurofast, 4 Pin (see wiring diagram, page 17)	1
	124595	CONNECTOR, Eurofast, 5 Pin (see wiring diagram, page 17)	1

▲ Replacement Danger and Warning labels, tags and cards are available at no cost.

❖ Also order Ref 27, Part No. 123025 and Ref 60, Part No. 16D984

† Also order Ref. 57, Part No. 117156 when ordering this part.

## Pressure Relief Valves

**Important Information regarding Pressure Relief Valve 16C807.**

◆ **Pressure Relief Valve 16C807 can only be used on the G3 Pump.** It is not intended for use with any other products.

The pressure relief valve uses a pressure adjustment screw (a) to set the pressure release point. **It is not intended as a way to relieve pressure during normal operation,** but as a protective measure in the event there is an unintended pressure increase in the system. Do not use this pressure relief valve as a means of relieving pressure in day-to-day, normal cycle operation.

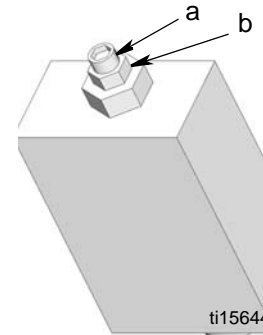

a = adjustment screw  
b = locking nut

The pressure adjustment screw will require periodic adjustments.

Whenever the valve is set/adjusted (after the set point is found) it is important to ensure that the valve is not bottomed out and there is at least 1/2 turn of adjustment remaining. This is determined by turning the screw (a) 1/2 turn and then back turning it out again.

**NOTE:** Turning adjustment screw (a) clockwise increases pressure.

Part	Description	Qty
16C807◆	VALVE, pressure relief, 500-3500 psi (3.44 MPa, 34.4 bar - 24.1 MPa, 241 bar), Set pressure 3000 psi $\pm$ 10% (20.68 MPa, 206.8 bar $\pm$ 10%) Included in Kit 571028	1
563156	VALVE, pressure relief, 750 psi (5.17 MPa, 51.71 bar)	1
563157	VALVE, pressure relief, 1000 psi (6.89 MPa, 68.95 bar)	1
563158	VALVE, pressure relief, 1500 psi (10.34 MPa, 103.42 bar)	1
563159	VALVE, pressure relief, 2000 psi (13.78 MPa, 137.89 bar)	1
563160	VALVE, pressure relief, 2500 psi (17.23 MPa, 172.36 bar)	1
563161	VALVE, pressure relief, 3000 psi (20.68 MPa, 206.84 bar)	1



### Installation and Repair Kits

Kit No.	Description	Manual Number
571026	KIT, output union, 3 pump	3A0523
571063	KIT, output union, 2 pump	
571028	KIT, return to reservoir NPT, includes pressure relief valve 16C807	3A0525
571071	KIT, return to reservoir BSPP, includes pressure relief valve 16C807	
24M478	KIT, vent valve, 12 volt DC, NO, NPT DEU	3A0526
24M479	KIT, vent valve, 24 volt DC, NO, NPT DEU	
24M480	KIT, vent valve, 115 VAC, NO, NPT, DIN	
24N182	KIT, vent valve, 230 VAC	
571036	KIT, cover with "G" label	NA
571041	KIT, pump element, includes Ref 17, 18, 33	3A0533
571042	KIT, repair, 2 liter reservoir, includes Ref 13, 36, 40	3A0534
571069	KIT, repair, 2 liter reservoir, for models with follower plate, includes Ref 13, 36, 40	
571044	KIT, replacement, paddle, 2 liter, for models without follower plate, includes Ref 13, 16, 35, 57	3A0535
571045	KIT, replacement, paddle, 2 liter, for models with follower plate, includes Ref 13, 16, 35, 40a, 42, 57	
571046	KIT, replacement, paddle, 4-16 liter, for models without follower plate, includes Ref 13, 16, 35, 57	
571047	KIT, replacement, paddle, 4 liter, for models with follower plate, includes Ref 13, 16, 35, 57	
571058	KIT, output adapter, NPT	3A0522
571070	KIT, output, adapter, BSPP	
571060	KIT, fill, zerk, leakproof	NA
571179	KIT, repair, reservoir oil, 2 liter models, includes Ref 13, 36, 40b	3A0534
571182	KIT, repair, reservoir, oil 4 liter models, includes Ref 13, 36, 40b	
571183	KIT, repair, reservoir, grease, 4 liter models, includes Ref 13, 36, 40b	

### Reservoir Conversion Kits

Kit No.	Description	Manual Number
571155	KIT, reservoir conversion, 4 Liter	3A1260
571156	KIT, reservoir conversion, 8 Liter	
571157	KIT, reservoir conversion, 12 Liter	
571158	KIT, reservoir conversion, 16 Liter	

### Fuses

Part	Description	Qty
571039	FUSE, 12 volt DC	1
571040	FUSE, 24 volt DC	1

# Technical Data

Pump Output Pressure	5100 psi (35.1 MPa, 351.6 bar)
Fill Inlet Pressure	5000 psi (34.4 MPa, 344.7 bar)
Power	
100-240 VAC	88 - 264 VAC; 0.8 A current, 90 VA Power, 47/63 Hz, Single phase, inrush/locked rotor, max 40A (1ms)
12 VDC	9 - 16 VDC; 5 A current, 60 W, inrush/locked rotor 12 A
24 VDC	18 - 32 VDC; 2.5 A current, 60 W, inrush/locked rotor 6 A
Outputs - Low Level (Dry Contact)	
Contact Rating	10 Watts Maximum
Switch Rating	200 VDC Maximum
Switching Current	0.5 A Maximum
Carry Current	1.2 A Maximum
Fluid	
Grease Models	Grease NLGI 000 - #2
Oil Models	At least 40 cSt oil.
Pumps	Up to 3
Pump Output	0.12 in. <sup>3</sup> (2 cm <sup>3</sup> ) / minute per outlet - 2 spacers 0.18 in. <sup>3</sup> (3 cm <sup>3</sup> ) / minute per outlet - 1 spacer 0.25 in. <sup>3</sup> (4 cm <sup>3</sup> ) / minute per outlet - 0 spacers
Pump Outlet	1/4-18 NPSF. Mates with 1/4-18 NPT male fittings
Reservoir Size	2, 4, 8, 12, 16 Liters
IP Rating	IP69K
Ambient Temps	-40°F - 158°F (-40°C to 70°C)
Weight (Dry - includes power cord and plug)	
Without follower plate	13.3 lbs (6.03 kg)
With follower plate	14.2 lbs (6.44 kg)
Wetted Parts	nylon 6/6 (PA), amorphous polyamide, T5004-060, zinc plated steel, carbon steel, alloy steel, stainless steel, nitrile rubber (buna-N), bronze, nickel plated alnico, chemically lubricated acetal, aluminum, PTFE
Sound Data	<60 dB

## Dimensions

Model	Height		Width		Depth	
	Inches	cm	Inches	cm	Inches	cm
2L	13.25	33.65	8.00	20.32	9.00	22.86
4L	14.50	36.83	9.25	23.50	10.00	25.40
8L	18.50	47.00	9.25	23.50	10.00	25.40
12L	23.00	58.42	9.25	23.50	10.00	25.40
16L	27.50	69.85	9.25	23.50	10.00	25.40

# Mounting Pattern

(For correct mounting configuration, choose either Option 1 or Option 2). See P/N 126916 template.

## Option 1

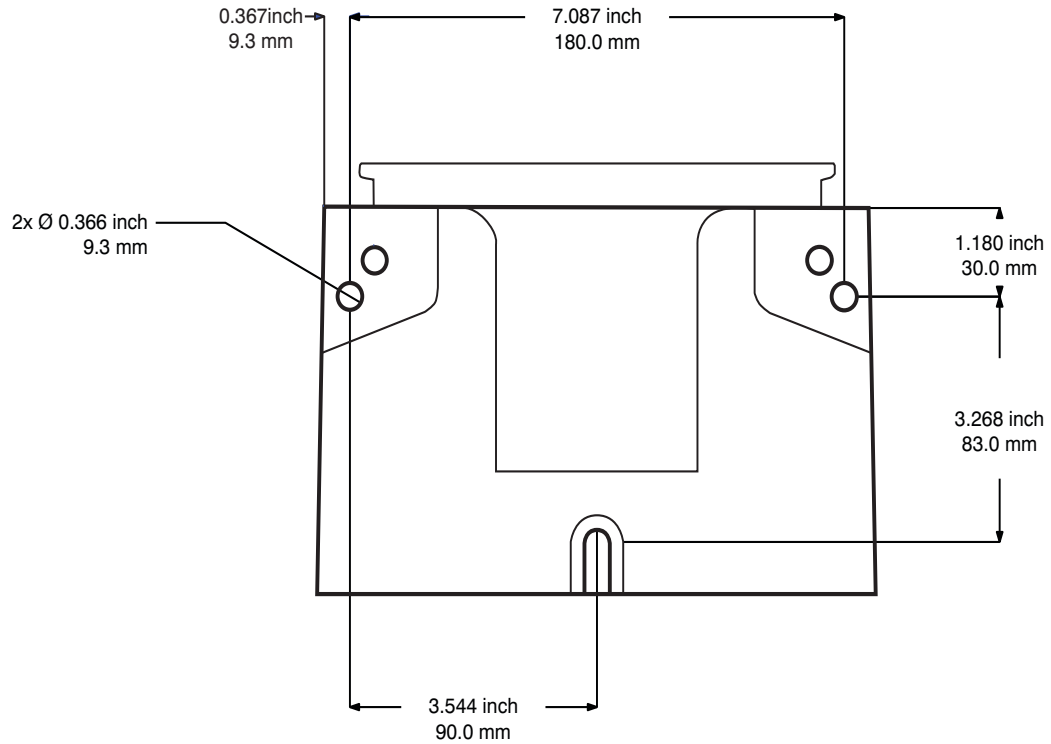

## Option 2

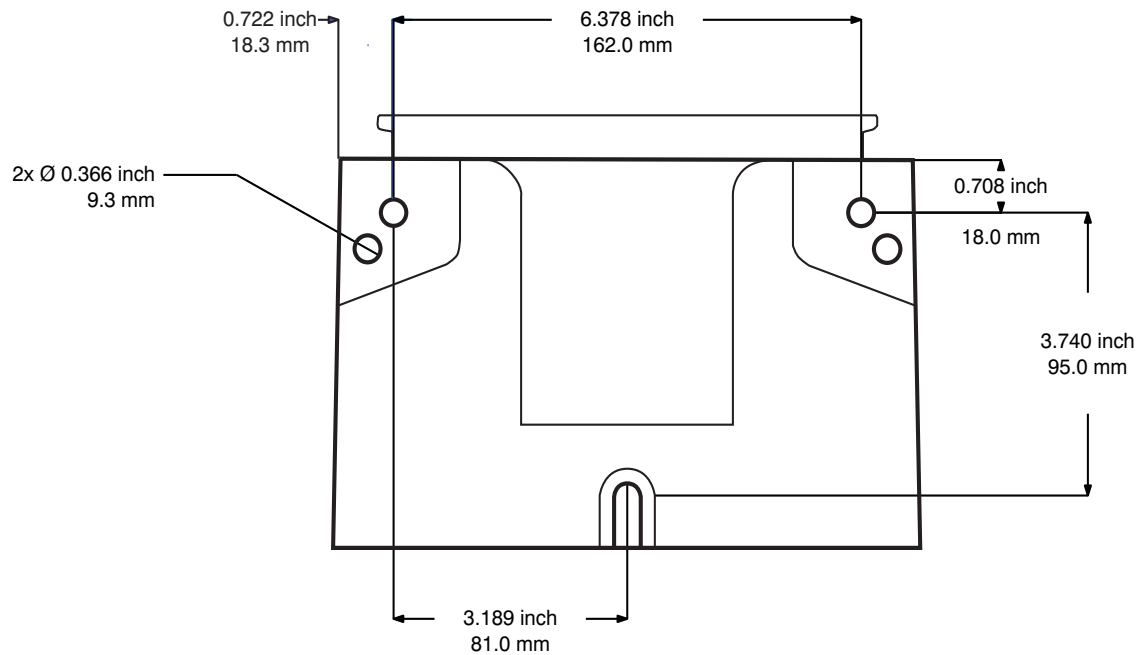

FIG. 30

# Graco Standard Warranty

Graco warrants all equipment referenced in this document which is manufactured by Graco and bearing its name to be free from defects in material and workmanship on the date of sale to the original purchaser for use. With the exception of any special, extended, or limited warranty published by Graco, Graco will, for a period of twelve months from the date of sale, repair or replace any part of the equipment determined by Graco to be defective. This warranty applies only when the equipment is installed, operated and maintained in accordance with Graco's written recommendations.

This warranty does not cover, and Graco shall not be liable for general wear and tear, or any malfunction, damage or wear caused by faulty installation, misapplication, abrasion, corrosion, inadequate or improper maintenance, negligence, accident, tampering, or substitution of non-Graco component parts. Nor shall Graco be liable for malfunction, damage or wear caused by the incompatibility of Graco equipment with structures, accessories, equipment or materials not supplied by Graco, or the improper design, manufacture, installation, operation or maintenance of structures, accessories, equipment or materials not supplied by Graco.

This warranty is conditioned upon the prepaid return of the equipment claimed to be defective to an authorized Graco distributor for verification of the claimed defect. If the claimed defect is verified, Graco will repair or replace free of charge any defective parts. The equipment will be returned to the original purchaser transportation prepaid. If inspection of the equipment does not disclose any defect in material or workmanship, repairs will be made at a reasonable charge, which charges may include the costs of parts, labor, and transportation.

**THIS WARRANTY IS EXCLUSIVE, AND IS IN LIEU OF ANY OTHER WARRANTIES, EXPRESS OR IMPLIED, INCLUDING BUT NOT LIMITED TO WARRANTY OF MERCHANTABILITY OR WARRANTY OF FITNESS FOR A PARTICULAR PURPOSE.**

Graco's sole obligation and buyer's sole remedy for any breach of warranty shall be as set forth above. The buyer agrees that no other remedy (including, but not limited to, incidental or consequential damages for lost profits, lost sales, injury to person or property, or any other incidental or consequential loss) shall be available. Any action for breach of warranty must be brought within two (2) years of the date of sale.

**GRACO MAKES NO WARRANTY, AND DISCLAIMS ALL IMPLIED WARRANTIES OF MERCHANTABILITY AND FITNESS FOR A PARTICULAR PURPOSE, IN CONNECTION WITH ACCESSORIES, EQUIPMENT, MATERIALS OR COMPONENTS SOLD BUT NOT MANUFACTURED BY GRACO.** These items sold, but not manufactured by Graco (such as electric motors, switches, hose, etc.), are subject to the warranty, if any, of their manufacturer. Graco will provide purchaser with reasonable assistance in making any claim for breach of these warranties.

In no event will Graco be liable for indirect, incidental, special or consequential damages resulting from Graco supplying equipment hereunder, or the furnishing, performance, or use of any products or other goods sold hereto, whether due to a breach of contract, breach of warranty, the negligence of Graco, or otherwise.

## **FOR GRACO CANADA CUSTOMERS**

The Parties acknowledge that they have required that the present document, as well as all documents, notices and legal proceedings entered into, given or instituted pursuant hereto or relating directly or indirectly hereto, be drawn up in English. Les parties reconnaissent avoir convenu que la rédaction du présente document sera en Anglais, ainsi que tous documents, avis et procédures judiciaires exécutés, donnés ou intentés, à la suite de ou en rapport, directement ou indirectement, avec les procédures concernées.

## Graco Information

For the latest information about Graco products, visit [www.graco.com](http://www.graco.com).

**TO PLACE AN ORDER**, contact your Graco distributor or call to identify the nearest distributor.

**Phone:** 612-623-6928 or **Toll Free:** 1-800-533-9655, **Fax:** 612-378-3590

*All written and visual data contained in this document reflects the latest product information available at the time of publication. Graco reserves the right to make changes at any time without notice.*

Original instructions. This manual contains English. MM 332291

**Graco Headquarters:** Minneapolis

**International Offices:** Belgium, China, Japan, Korea

**GRACO INC. AND SUBSIDIARIES • P.O. BOX 1441 • MINNEAPOLIS MN 55440-1441 • USA**  
**Copyright 2013, Graco Inc. All Graco manufacturing locations are registered to ISO 9001.**

[www.graco.com](http://www.graco.com)

Revision F, September 2016